

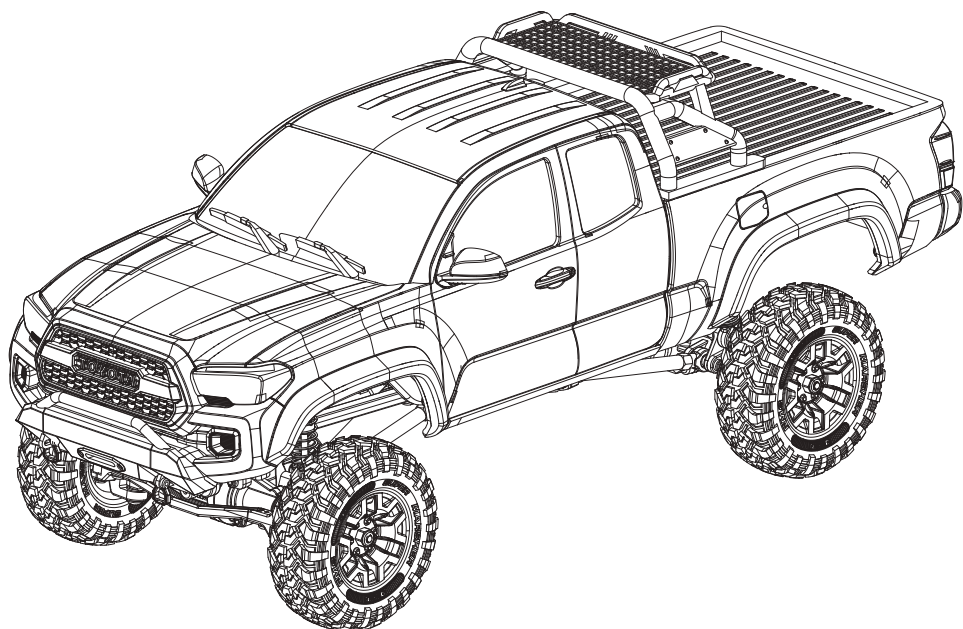

1/24 TOYOTA TACOMA



FCX24M

MAN-G0335

Instruction Manual
操作手册

Disclaimer and Warning 免责声明与警告

Thank you for purchasing our product. This product is composed of precision components and is not a toy. It is not suitable for use by individuals under the age of 14. Please do not allow children to come into contact with this product. Exercise extra caution when operating this product in the presence of children. This product is a remote-controlled model and will provide a smooth and easy operating experience when the power is functioning correctly, and all components are undamaged. Visit www.fms hobby.com to access the latest product manual and related supplementary instructions and warnings. We reserve the right to update this manual. If there are updates to this manual, they will not be notified separately.

Before using the product, please carefully read this product manual to understand your legal rights, responsibilities, and safety instructions. Failure to do so may result in property damage, safety incidents, and personal safety risks. Once you use this product, it is considered that you have understood, accepted, and agreed to all the terms and content of this manual. Users are responsible for their actions and all consequences arising from them. Users commit to using this product only for legitimate purposes and agree to all the terms and content in this manual as well as any relevant policies or guidelines that our company may establish. Our company and distributors are not liable for any losses caused by users not following the product manual. In compliance with laws and regulations, our company reserves the final interpretation of this manual. Our company has the right to update, revise, or terminate these terms without prior notice.

This manual is intended to assist you in correctly operating, maintaining, and repairing the vehicle. Since most of the components involved in this product are unique parts, please keep this manual for future reference.

感谢您购买我们的产品。本产品由精密部件组成，并非玩具，因此不适合 14 岁以下的人士使用。请勿让儿童接触本产品。在有儿童出现的场景操作时请务必特别小心注意。本产品是一款遥控模型产品，在电源正常工作及各部件未损坏的情况下将提供轻松自如的操作体验。请访问以下网址www.fms hobby.com获取最新的产品手册及相关附加说明与警告。我司保留更新本手册的权力。本手册如有更新，恕不另行通知。

请务必在使用产品之前仔细阅读本产品手册，了解您的合法权益、责任和安全说明，否则，可能带来财产损失、安全事故和人身安全隐患。一旦使用本产品，即视为您已理解、认可和接受本手册全部条款和内容。使用者承诺对自己的行为及因此而产生的所有后果负责。使用者承诺仅出于正当目的使用本产品，并且同意本手册内的全部条款和内容及我司可能制定的任何相关政策或者准则。我司及分销商不承担因用户未按产品手册使用产品所引发的一切损失。在遵从法律法规的情况下，我司享有对本手册的最终解释权。我司有权在不事先通知的情况下，对本条款进行更新改版或终止。

本手册旨在帮助您正确操作、维护和修理车辆。由于本品所涉部件多数为特有部件，请保留本手册作为未来参考之用。

Safety, precautions and warnings 安全、预防措施及警告

- Replace damaged components with original factory-parts. Pay special attention to the polarity of all vehicle wiring.
- Use common sense when selecting the environment to operate your vehicle. Do not operate near power cables, cellular/radio towers, deep water or unstable terrain. The operator is solely responsible for their actions.
- The product is composed of precision electrical components. It is critical to keep the product away from moisture and other contaminants.
- Always check the radio range of the vehicle prior to operation in order to prevent radio loss or interference.
- Operate this product within your ability. If the vehicle is dangerous to retrieve, it never worth the risk.
- Always turn on the transmitter before connecting the battery on the model. When turning off the model, always disconnect the battery first, and then turn off the transmitter. If this order is reversed, the model

may become uncontrollable and cause serious damage.

- Never allow transmitter batteries to run low as it may cause loss of vehicle control.
- Plastics on the vehicle are susceptible to damage or deformation due to extreme heat and cold climate. Do not store the model near any source of heat such as oven or heater. Store the model indoors, in a climate-controlled, room temperature environment.

- 请使用原厂部件更换损坏的部件。特别注意所有车辆接线的正负极。
- 务必选择合适的环境操作遥控模型，所选环境需远离电缆、无线电塔、深水及不稳定地形。本品操作者对其行为全权负责。
- 本品由精密电子部件构成。请勿将本品暴露于潮湿的环境或者其他污染物中。
- 确保每次操作前检查车辆的无线接收范围，以防止无线信号丢失或受干扰。
- 在您的能力范围内操作此产品。在任何时候，如果车辆操作有危险，则绝对不值得冒险。
- 通电方式：务必先开遥控器再将车子通电。断电方式：务必先将车子断电再关遥控器。以上顺序如逆转，则可能引起遥控模型失控，导致人身伤害或财产损失。
- 遥控器电池低电时，请勿操作模型车，以免出现失控。
- 模型产品上的塑胶件容易因极冷或极热气候出现变形或损坏的状况。所以请将模型产品存放在气候受控的室温环境中，切勿靠近任何热源，如烤箱或加热器等。

This product is not a toy! (14+) Recommended for ages 14 and up. Adult supervision required for ages under 14 years old. Contains small parts, keep out of reach of children 3 years of age and younger.

使用前请仔细阅读本手册。我们不对任何故意损坏或不当使用负责。这个产品不是玩具！建议14岁及以上者使用。14岁以下的用户，需要在成年人监督下使用。本产品部分包含小零件，请务必保证3岁及以下儿童不能接触本产品。

Safety symbols 安全符号

Pay close attention to the following symbols and their meanings. Failure to follow these warnings could cause damage, injury or death.

仔细阅读以下符号及其相关说明，如不按照以下指引进行操作，可能会导致设备损坏或人员伤亡。

 Danger 危险	Not following these instructions may lead to serious injuries or death. 如果使用者不按照说明方法操作，有可能导致操作者或他人受到严重受伤，甚至遭受生命危险。
---	--

 Warning 危险	Not following these instructions may lead to major injuries. 如果使用者不按照说明方法操作，有可能导致操作者或他人受到轻微伤害。
---	--

 Caution 危险	Not following these instructions may lead to minor injuries. 如果使用者不按照说明方法操作，可能导致操作者或他人轻微伤害。
---	---

Safety guide 安全信息

Prohibited 禁止

- Do not use the product at night or in bad weather like rain or thunderstorm. It can cause erratic operation or loss of control.
- Do not use the product when visibility is limited.
- Do not use the product on rain or snow days. Any exposure to moisture (water or snow) may cause erratic operation or loss of control.
- Interference may cause loss of control. To ensure the safety of you and others, do not operate in the following places:
 1. Near any site where other radio control activity may occur

2. Near power lines or communication broadcasting antennas
3. Near people or roads
4. On any body of water when passenger boats are present

- Do not use this product when you are tired, uncomfortable, or under the influence of alcohol or drugs. Doing so may cause serious injury to yourself or others.

- The 2.4GHz radio band is limited to line of sight. Always keep your model in sight as a large object can block the RF signal and lead to loss of control.

- Do not touch any part of the model that may generate heat during operation, or immediately after use. The engine, motor or speed control, may be very hot and can cause serious burns.

- 请不要在夜晚或雷雨天气使用本产品，恶劣的天气环境有可能导致遥控设备失灵。

- 请不要在能见度有限的情况下使用本产品。

- 请不要在雨雪或有水的地方使用本产品。如果有液体进入到系统内部，可能会导致运行不稳定或失灵。

- 信号干扰可能导致设备失控。为保证您和他人安全，请不要在以下地点使用本产品：

- 1、通信基站附近或其他无线电活跃的地方

- 2、人多的地方或道路附近

- 3、水域附近

- 4、高压电线或通信广播天线附近

- 当您感到疲倦、不舒服，或在摄入酒精或服食导致麻醉或兴奋的药物后，不要操作本产品。否则可能对自己或他人造成严重的伤害。

- 2.4GHz无线电波段完全不同于之前所使用的低频无线电波段。使用时请确保模型产品在您的视线范围内，大的障碍物将会阻断无线电频率信号从而导致遥控失灵模型失控。

- 请勿在操作过程中或使用后立即触摸模型可能产生热量的任何部分。发动机、电机或速度控制器可能非常热，并可能导致严重烧伤。

Mandatory 强制

- Misuse of this product may lead to serious injury or death. To ensure the safety of you and your equipment, read this manual and follow the instructions.

- Make sure the product is properly installed in your model. Failure to do so may result in serious injury.

- Make sure to disconnect the receiver battery before turning off the transmitter. Failure to do so may lead to unintended operation and cause an accident.

- Ensure that all servos operate in the correct direction. If not, adjust the direction first.

- Make sure the model stays within the systems maximum range to prevent loss of control.

- 遥控设备使用不恰当可能导致操作者或他人严重受伤，甚至死亡。为保证您和设备的安全，请仔细阅读使用说明并按照要求进行操作。

- 使用前必须确保本产品与模型安装正确，否则可能导致模型发生严重损坏。

- 关闭时，请务必先关闭接收机电源，然后关闭发射机。如果关闭发射机电源时接收机仍然在工作，将有可能导致遥控设备失控或者引擎继续工作而引发事故。

- 操控时，请先确认模型所有舵机的动作方向与操控方向一致。如果不一致，请调整好正确的方向。

- 当遥控距离较远时，有发生失控的可能，请适当缩短遥控距离。

DoC Declaration DoC 自我说明

Hereby, we declare that the Radio Equipment [FMS-G3&FMS-R3A] is in compliance with RED 2014/53/EU.
特此，我们声明无线电设备【FMS-G3&FMS-R3A】符合 RED 2014/53/EU。

UKCA Required:

ETSI EN 301 489-1 V2.2.3 (2019-11)

BS EN 62311:2008

ETSI EN 301 489-17 V3.2.4 (2020-09)

BS EN IEC 62368-1:2020+A11:2020

ETSI EN 300 328 V2.2.2(2019-07)

CE Warning CE 警告语

The antenna(s) used for this transmitter must be installed to provide a separation distance of at least 20 cm from all persons and must not be co-located or operating in conjunction with any other transmitter. End-users and installers must be provided with antenna installation instructions and transmitter operating conditions for satisfying RF exposure compliance.

发射机的天线必须距离所有人员或其他发射机至少20厘米的间隔距离。必须将天线安装说明和满足射频讯号辐射的发射机操作规范提供给终端用户和安装人员。

Appendix 1 FCC Statement

This equipment has been tested and found to comply with the limits for a Class B digital device pursuant to part 15 of the FCC rules. These limits are designed to provide reasonable protection against harmful interference in a residential installation. This equipment generates, uses and can radiate radio frequency energy and, if not installed and used in accordance with the instructions, may cause harmful interference to radio communications.

However, there is no guarantee that interference will not occur in a particular installation. If this equipment does cause harmful interference to radio or television reception, which can be determined by turning the equipment off and on, the user is encouraged to try to correct the interference by one or more of the following measures:

- Reorient or relocate the receiving antenna.
- Increase the separation between the equipment and receiver.
- Connect the equipment into an outlet on a circuit different from that to which the receiver is connected.
- Consult the dealer or an experienced radio/TV technician for help.

To assure continued compliance, any changes or modifications not expressly approved by the party responsible for compliance could void the user's authority to operate this equipment. (Example use only shielded interface cables when connecting to computer or peripheral devices).

This equipment complies with Part 15 of the FCC Rules. Operation is subject to the following two conditions:

- (1) This device may not cause harmful interference, and
- (2) This device must accept any interference received, including interference that may cause undesired operation.

Caution!

The manufacturer is not responsible for any radio or TV interference caused by unauthorized modifications to this equipment. Such modifications could void the user authority to operate the equipment.

1. Move all your channels to the desired position.
2. Select [All channels] and then [Yes] in the confirmation box.

Environmentally friendly disposal

Old electrical appliances must not be disposed of together with the residual waste, but have to be disposed of separately. The disposal at the communal collecting point via private persons is for free. The owner of old appliances is responsible to bring the appliances to these collecting points or to similar collection points. With this little personal effort, you contribute to recycle valuable raw materials and the treatment of toxic substances.



FCC ID: 2A2UNR3A00

Product Introduction

产品简介

Background 产品背景

Before it was officially named Tacoma in 1995, this truck was widely known in North America simply as the Toyota Pickup. It was essentially an upgraded, U.S.-focused version of the Hilux—created in response to American drivers' feedback that the Hilux felt "too utilitarian," with basic features and modest power.

Toyota responded by giving the truck a more refined ride, better comfort, and family-friendly upgrades, but held off on a formal name until 1995. That's when they launched the Tacoma, named after the active volcano in Washington State, a symbol of rugged strength and explosive capability.

What started as an enhanced Hilux quickly became a benchmark for midsize pickups. Marketed as the "Premium Hilux," the Tacoma offered features well beyond a typical work truck—better comfort, stronger capability, and impressive payload. By 2000 it came standard with daytime running lights, ABS, stability control, and side airbags, while still maintaining an affordable price.

The Tacoma quickly took over the segment, becoming America's best-selling midsize pickup for 13 straight years and surpassing one million units sold. It embodies Toyota's commitment to durability, innovation, and the spirit of adventure captured in their slogan: "Let's Go Places."

1995年正式命名"Tacoma"之前，这款卡车在北美一直被简称为"丰田皮卡"。它本质上是海拉克斯的升级版---专为美国市场打造，旨在回应美国用户对海拉克斯"过于工具化"的反馈（基础配置普通、动力中庸）。

丰田为此提升了车辆的驾乘质感、舒适性和家庭友好属性，但直到1995年才赋予其正式名称。这一年，它以华盛顿州活火山"塔科马"命名，象征强悍性能与爆发力。

这款强化版海拉克斯迅速成为中型皮卡标杆。作为"豪华版海拉克斯"，TACOMA（塔科马）凭借超越工具卡的豪华配置、更优舒适性和惊人载重能力颠覆市场。至2000年，其标配日间行车灯、ABS防抱死、车身稳定控制和侧气囊，同时保持亲民价格。

Tacoma迅速统治细分市场，蝉联美国中型皮卡销量冠军13年，累计销量破百万。它诠释了丰田对耐用性、创新精神的坚守，更践行了"踏上想象之旅"的冒险哲学。

About Model 产品介绍

FMS proudly carries that same legacy into the RC world with the FMS TACOMA, a meticulously crafted scale replica that delivers big-truck adventure in a small, go-anywhere package. Built with the same attention to detail that made the full-size Tacoma a legend, this model is designed to let you explore new terrain and push your limits—just like its real-world counterpart.

Its ABS hard-body shell is produced with precision molding to capture every detail, including the grille, bumpers, wheel arches, mirrors, tailgate, wipers, and door handles. It's available in three factory-matched colors: Gray, Red, and Blue—true to the original Tacoma's iconic paint schemes.

Underneath, the truck rides on the all-new FMS FCX24M platform with an extended 153 mm (6.02-inch) wheelbase. Its rugged ladder-frame chassis and high-strength solid axles deliver excellent rigidity and torsional strength. Specially designed off-road tires use a soft rubber compound and deep tread pattern for incredible grip and ground clearance—perfect for tackling obstacles and rough terrain.

It's also the first in its class to feature a two-speed transmission, paired with a powerful 050 motor for impressive performance. A factory-included 380 mAh 2S LiPo battery delivers around 30 minutes of high-speed runtime. Compact yet capable, it navigates indoor “micro-terrain” (books, phones, keyboards) with ease and conquers outdoor trails with confidence.

With the FMS Tacoma, you're not just driving an RC truck—you're carrying forward the same rugged dependability and adventurous spirit Toyota built into every full-size Tacoma. FMS brings Toyota's core strengths of quality, innovation, and go-anywhere fun straight to the RC crawler market. Let's Go Places—anywhere your imagination takes you.

FMS将传奇基因注入RC领域，推出精心打造的TACOMA比例模型，以小尺寸车身承载全尺寸卡车的探险灵魂。本模型承载实车精益求精的工艺，助您探索未知地形、突破极限——正如其原型车一般。

ABS硬质车壳采用精密模具成型，精准复刻格栅、保险杠、轮眉、后视镜、尾门、雨刷及门把手等细节。提供灰/红/蓝三色，完美匹配实车经典涂装。

底盘搭载全新FCX24M平台，轴距延至153毫米（6.02英寸）。梯形大梁底盘与高强度整体桥组合，赋予卓越车身刚性与抗扭性。特制越野轮胎采用橡胶配方与深胎纹，抓地力出众且离地间隙优越，轻松征服障碍与崎岖地形。

同级别首配双速变速箱，结合强劲050电机释放澎湃性能。原厂380mAh容量的2S锂电支持约30分钟高速续航。小巧机身不惧挑战：室内跨越书本/手机/键盘构筑的“微地形”，户外横扫山林小径从容自信。

驾驭FMS的TACOMA，您不仅操控RC模型，更传承了丰田赋予全尺寸TACOMA的强悍可靠与冒险精神。FMS将丰田品质核心——精工品质、创新科技、全域乐趣——注入RC攀爬车领域。即刻启程，让想象指引征途。

Features 特点

- TOYOTA-LICENSED ABS HARD BODY – A TRUE-TO-SCALE REPLICA OF THE ICONIC TACOMA
- NEXT-GENERATION FCX24M CHASSIS ● HEAVY-DUTY TRAPEZOIDAL METAL CROSSMEMBER FOR IMPROVED STRENGTH AND DURABILITY ● TWO-SPEED TRANSMISSION – IDEAL FOR BOTH OFF-ROADING AND CLIMBING ● LARGE-DIAMETER TIRES FOR INCREASED GROUND CLEARANCE ● FACTORY-INSTALLED ROOF RACK ● COUNTER-ROTATING DRIVESHAFTS FOR SMOOTHER, MORE REALISTIC HANDLING
- 丰田授权ABS车壳 - 精准还原经典 ● 新一代FCX24M底盘 ● 重型梯形金属大梁，强化结构耐久性 ● 双速变速箱，攀爬越野双重优势 ● 大直径轮胎，提升离地间隙 ● 原厂标配车顶行李架 ● 反传结构，使行驶姿态更平顺仿真

Specification 产品参数

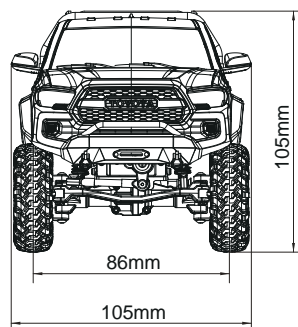
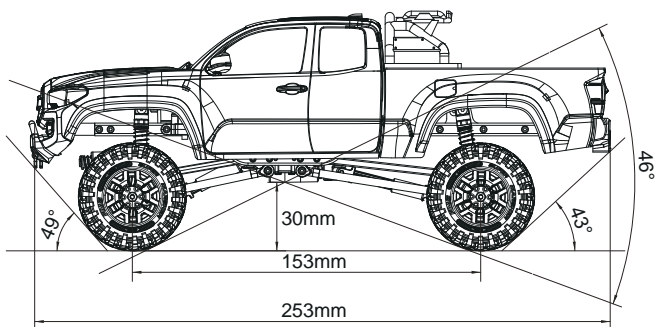

- Length: 253mm
- Width: 105mm
- Height: 105mm
- Wheelbase: 153mm
- Tread : 86mm
- Ground Clearance: 30mm
- Approach Angle: 49°
- Departure Angle: 43°
- Tire Size: $\Phi 47*17$ mm
- Transmitter: G3
- Receiver: R3A transmitter, receiver with ESC group control board
- Light Control: None
- Recommend Battery: 2S Lipo 7.4V, 380mAh
- Motor Type: 050 motor
- Bearing: All metal bearings
- Drive System: 4WD
- Waterproof Class: Splash-proof
- Maximum Speed: 2km/h, 5km/h
- Runtime: 30min
- Maximum Control Distance: The remote control supports a remote distance of over 80 meters in open areas

- 车长: 253mm
- 车宽: 105mm
- 车高: 105mm
- 轴距: 153mm
- 轮距: 86mm
- 离地距离: 30mm
- 接近角: 49°
- 离去角: 43°
- 轮胎: $\Phi 47*17$ mm
- 发射型号: G3
- 接收/电调型号: R3A 二合一电调 10A
- 灯控型号: 无
- 推荐电池: 2S 锂电 7.4V, 380mA
- 电机: 050电机
- 轴承: 全车金属轴承
- 驱动形式: 4WD
- 是否防水: 防溅水
- 最大速度: 2km/h, 5km/h
- 续航: 30分钟
- 最大遥控距离: 遥控器可支持空旷场地80M以上的遥控距离

Transmitter instruction 发射机介绍

The product adopts the 2.4GHz AFHDS 2A-BS Automatic Frequency Hopping Digital System which consist of FMS-G3 transmitter and FMS-R3A receiver. It supports two-way transmission, featuring 3-channel and compatible with variety of car models.

本系统采用 2.4GHz AFHDS 2A-BS 协议，由 FMS-G3 发射机和 FMS-R3A 接收机组成。支持双向传输、共输出 3 个通道、兼容多种车模型。

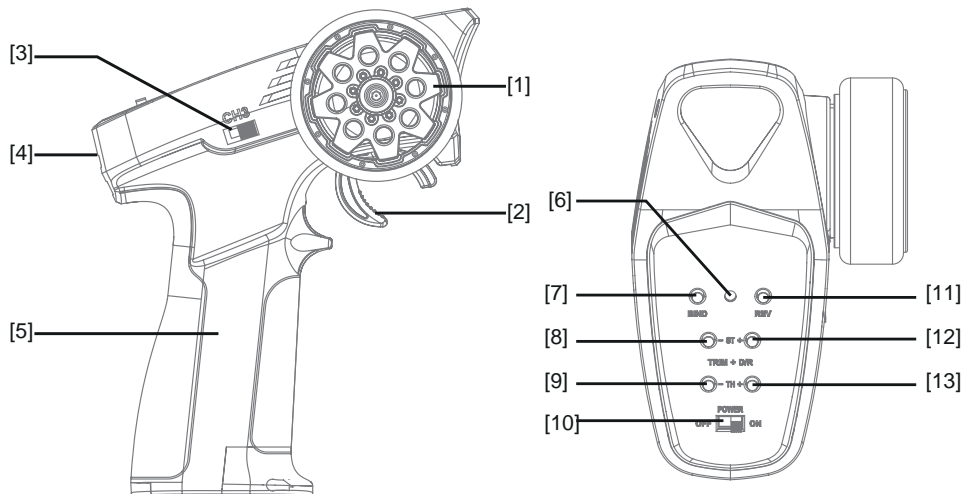

[1] Steering Wheel CH1
方向手轮 CH1

[2] Throttle Trigger CH2
油门扳机 CH2

[3] Three-position Switch CH3
三档开关 CH3

[4] Lanyard Eye
挂绳孔

[5] Handle, AAA*4 batteries can be installed inside
手柄，内可安装 AAA*4 电池

[6] LED
指示灯

[7] BIND Button (Binding, turn on or off the car light
or reset data)
BIND 按键 (对码、开启关闭车灯或数据复位)

[8] ST- Button (To decrease the trim and travel
value of CH1)
ST- 复位按键 (减小 CH1 微调 and 舵量)

[9] TH- Button (To decrease the trim and travel
value of CH2)
TH- 复位按键 (减小 CH2 微调 and 舵量)

[10] Power Switch
电源开关

[11] REV Button (To reverse the CH1 or CH2)
REV 复位按键 (控制 CH1 或 CH2 方向)

[12] ST+ Button (To increase the trim and travel
value of CH1)
ST+ 复位按键 (增加 CH1 微调 and 舵量)

[13] TH+ Button (To increase the trim and travel
value of CH2)
TH+ 复位按键 (增加 CH2 微调 and 舵量)

Transmitter Specifications 发射机规格

• Product Model: FMS-G3	• 产品型号: FMS-G3
• Compatible Receivers: FMS-R3A	• 适配接收机: FMS-R3A
• Compatible Models: 1:18, 1:24 simulation cars or climbing cars	• 适配模型: 1:18、1:24 仿真或攀爬准模型车
• Number of Channels: 3	• 通道个数: 3
• RF: 2.4GHz ISM	• 无线频率: 2.4GHz ISM
• Maximum Power : <20dBm (e.i.r.p.) (EU)	• 发射功率: < 20dBm
• 2.4G Protocol: AFHDS 2A-BS	• 无线协议: AFHDS 2A-BS
• Distance: >100m(Ground distance without interference)	• 遥控距离: >100m (空旷无干扰地面距离)
• Resolution: 1024	• 通道分辨率: 1024 级
• Input Power: 6V DC or 1.5AAA*4	• 输入电源: 6V DC 或 1.5AAA*4
• Working Current: 10mA (Static); 120mA/6V (Dynamic)	• 工作电流: 10mA (静态) ; 120mA/6V (动态)
• Charging Port: No	• 充电接口: 无
• Low Voltage Alarm: < 4.2V	• 低电压报警: < 4.2V
• Antenna: Built-in single antenna	• 天线类型: 内置单天线
• Data Port: No	• 数据接口: 无
• Temperature Range: -10°C ~ +60°C	• 温度范围: -10°C~+60°C
• Humidity Range: 20% ~ 95%	• 湿度范围: 20%~95%
• Online Update: No	• 在线更新: 无
• Color: Blue	• 发射机颜色: 蓝色
• Dimensions: 115.2*75.5*145mm	• 外形尺寸: 115.2*75.5*145mm
• Weight: About 113g	• 机身重量: 113g 左右
• Certification: CE, FCC ID: 2A2UNG300	• 认证: CE, FCC ID: 2A2UNG300

Overview Instruction

接收机概览

Overview 接收机

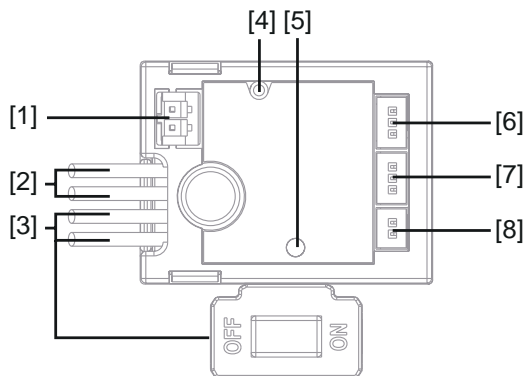

- [1] Motor Interface
马达接口
- [2] Battery Lines(Molex51005 Female Interface)
电池接线 (Molex51005 母座接口)
- [3] Power Switch
开关盒
- [4] Antenna
天线
- [5] LED
指示灯
- [6] CH3
频道3
- [7] CH1
频道1
- [8] Car Light
车灯

Overview Specifications 产品规格

• Product Model: FMS-R3A	• 产品型号: FMS-R3A
• Compatible Transmitters: FMS-G3	• 适配发射机: FMS-G3
• Compatible Models: 1:18, 1:24 simulation cars or climbing cars	• 适配模型: 1: 18、1: 24 仿真或攀爬准模型车
• Applicable Motors: 050 motor set	• 适配电机: 050电机套装
• PWM Channels:2	• PWM 通道: 2
• Number of Lights:1	• 车灯组数: 1
• RF: 2.4GHz ISM	• 无线频率: 2.4GHz ISM
• 2.4GHz Protocol: AFHDS 2A-BS	• 无线协议: AFHDS 2A-BS
• Input Power: 2S LiPo battery	• 输入电源: 2S 锂电
• Input Power: 6V DC or 1.5AAA*4	• 持续 / 峰值电流: 10A/40A
• BEC Output: 5V/1A	• BEC 输出: 5V/1A
• Maximum Power: < 20dBm (e.i.r.p.) (EU)	• 发射功率: < 20dBm
• Distance: >100m (Ground distance without interference)	• 遥控距离: >100m (空旷无干扰地面距离)
• Antenna: External antenna	• 天线类型: 外置单天线
• Data Output: PWM	• 数据输出: PWM
• Resolution: 1024	• 通道分辨率: 1024 级
• Temperature Range: -10°C ~ +60°C	• 温度范围: -10°C~+60°C
• Humidity Range: 20% ~ 95%	• 湿度范围: 20%~95%
• Online Update: No	• 在线更新: 无
• Dimensions: 32*24.4*12mm	• 外形尺寸: 32*24.4*12mm
• Weight: 8g	• 机身重量: 8g 左右
• Waterproof: PPX4	• 防水等级: PPX4
• Certification: CE, FCC ID: 2A2UNR3A00	• 认证: CE, FCC ID: 2A2UNR3A00

The LED Status of the Receiver 接收机指示灯

The LED status indicates the power supply state of the receiver and its working state.

Off: The receiver is not powered on.

Light on in red: The receiver is connected to the power supply. It works normally.

Fast flashing: The receiver is in the bind mode.

Slow flashing: The LED flashes slowly when the transmitter is powered off, unbound, or no signal.

接收机状态指示灯用于指示接收机的电源及工作状态。

灭: 接收机电源未接通。

红灯常亮: 接收机已连接电源, 并正常工作。

快速闪烁: 接收机处于对码状态中。

慢速闪烁: 发射机未开机或未对码, 无信号情况。

Interface 接口

All the servos' interfaces and the car light interface are 1.25 mm standard pins, and the motor interface is PH2.0 female interface. They are for connecting the receiver to each terminal part of the model.

舵机接口和车灯接口均为 1.25 mm 的标准端子座，马达接口为 PH2.0 母座端子，用于连接接收机与模型的各个终端部件。

Antenna 接收机天线

It is an external antenna.
本接收机天线为外置单天线。

 **Caution**
小心 Do not pull the antenna of the receiver. Do not tie the antenna and the servo cable together.
不要拉扯接收机的天线，也不要将天线和舵机连接线绑在一起。

 **Note**
警告 Do not put the antenna close to the metal materials, because this will affect the signal strength of the receiver. Keep the receiver's antenna at least 1cm away from conductive materials such as carbon or metal.
接收机天线需远离导电材料，例如金属棒和碳纤维物质。为避免影响正常工作，请确保接收机天线和导电材料之间至少有 1cm 以上的距离。

Getting Started

使用前准备

Transmitter Antenna 发射机天线

The transmitter has a built-in antenna. When the transmitter starts to work, the antenna automatically operate, without additional operations.

Receiver and Servo Installation 接收机与舵机安装

Make sure that the receiver is mounted in an appropriate location within the model, to ensure a stable signal.

Pay attention to the following when installing the receiver:

1. Make sure the receiver is not installed near ESCs or other sources of electrical noise.
2. Keep the receiver's antenna away from conductive materials such as carbon or metal. To ensure normal function make sure there is a gap of at least 1cm between the antenna and the conductive material.

请结合相应模型的结构选择合适的位置安装接收机，同时为了确保接收机的性能和遥控距离的稳定，并防止外界干扰。

安装过程中请注意以下事项：







- 1、确保接收机安装在远离电机，电子调速器或电子噪声过多的区域。
- 2、接收机天线需远离导电材料，例如金属棒和碳纤维物质。为了避免影响正常工作，请确保接收机和导电材料之间至少有 1 厘米以上的距离。

 **Caution**
小心 To prevent damage do not power on the receiver during installation.
准备过程中，请勿连接接收机电源，避免造成不必要的损失。

Transmitter Battery Installation 发射机电池安装

Before operation, install the battery and connect the system as instructed below.
开始操作前，请按照本章的顺序和指引安装电池、连接设备。

 **Danger**
危险 Only use specified battery (X4 AAA batteries).
仅使用厂家指定的电池。

 Danger 危险	Do not open, disassemble, or attempt to repair the battery. 请勿打开、拆卸或自行维修电池。
 Danger 危险	Do not crush/puncture the battery, or short the external contacts. 请勿挤压、刺穿或接触电池的金属端子。
 Danger 危险	Do not expose to excessive heat or liquids. 请勿将电池置于高温环境或液体中。
 Danger 危险	Do not drop the battery or expose to strong shocks or vibrations. 请注意防止电池跌落、碰撞或振动。
 Danger 危险	Always store the battery in a cool, dry place. 请将电池存放在干燥阴凉的环境中。
 Danger 危险	Do not use the battery if damaged. 如果电池损坏，请立即停止使用。

Battery Type: AAA

Follow the steps below to install the batteries:

1. Open the battery compartment cover.
2. Insert 4 AAA batteries with the correct polarity. Make sure it is connected with the correct polarity to avoid damage.
3. Replace battery compartment cover.

Low battery alarm: When the battery is lower than 4.2V, the transmitter will give a alarm with the LED flashing slowly.

电池类型使用：AAA 电池

请按照以下步骤安装发射机电池：

- 1、打开电池仓盖；
- 2、将 4 颗电量充足的 AAA 电池装入电池仓内，注意正负极方向并确保电池上的金属端子与电池仓内的金属端子接触；
- 3、盖好电池仓盖。

低电量报警：当电量低于 4.2V 时，发射机即发出声音报警同时 LED 慢闪。

Instructions

操作指引

Power On 开机

Follow the steps below to turn on the transmitter:

1. Check to make sure that the batteries are fully charged and installed correctly.
2. Toggle the Power Switch to the [ON] position, and the LED will be solid on.
3. Connect the receiver to power.

Note: For safety always power on the transmitter before the receiver.

请按照以下步骤进行开机：

- 1、检查系统状态，确电池电量充足并正确安装；
- 2、将开关拨到 [ON] 位置，指示灯常亮；
- 3、接收机通电。

注：为保障模型及人员安全，使用时请先打开发射机再接接收机通电。

 Caution 小心	Operate with caution in order to avoid damage or injury. 此时系统已启动，请谨慎操作，否则可能导致产品损坏或人员伤亡。
--	--

The LED Status of the Transmitter 接收机与舵机安装

The LED status indicates the power supply state of the transmitter and its working state.

Off: The transmitter is not powered on.

Slow flashing: Low voltage alarm.

Fast flashing: The transmitter is in the bind mode.

Gradual: The transmitter is in Sleep mode or in Idle alarm state.

Three-flash-one-off: The transmitter is in standby state, while the bound receiver is powered off, unbound, or nosignal.

发射机状态指示灯用于指示发射机的电源及工作状态。

灭：发射机电源未接通。

慢速闪烁：低电压报警。

快速闪烁：发射机处于对码状态中。

呼吸灯闪烁：发射机处于休眠模式或闲置报警状态。

三闪一灭：发射机处于待机状态，但对码的接收机未开机、已关机或掉码。

Binding 对码

The transmitter and receiver have already been bound at the factory.

However if the receiver needs to be replaced or additional receivers bound follow these steps:

1. Turn on the transmitter while holding the bind button to put the transmitter into bind mode. Meanwhile the LED will flash quickly, and release the bind button.

2. The receiver will power on and wait for 1 second, if without connection, it will enter the binding state automatically.

3. The receiver's LED is solid on, indicating the binding is successful.

4. Check to make sure the transmitter and receiver functions are working correctly, repeat steps 1 to 3 (binding process) if any problems arise.

Note: If the binding is not completed within ten seconds, the LED of the receiver will enter its slow flashing state.

发射机和接收机在出厂前已对码成功。

如需更换其他的发射机或接收机，请按照下述步骤重新对码。本发射机支持双向传输，对码步骤如下：

1、按住发射机的 BIND 键，并将 POWER 键拨至 [ON] 位置，发射机即进入对码状态，此时发射机指示灯快闪，松开对码键；

2、接收机通电进入对码状态；

3、接收机 LED 灯常亮，即对码成功（发射机对码成功后自动退出对码状态）；

4、检查发射机、接收机是否正常工作。如需重新对码，请重复以上步骤。

注：若十秒内对码没有完成，接收机 LED 指示灯进入慢闪状态。

Stick Calibration 摇杆校准

This function is used to set the neutral position for throttle trigger and steering wheel.

Every transmitter is calibrated before leaving the factory, however if recalibration is required, please follow these

steps:

1. Turn and hold the wheel clockwise to the max travel point and push the throttle forwards as far as possible, then turn on the transmitter. It will enter calibration mode. The buzzer sounds shortly in cycle for prompt.

2. Turn the steering wheel to max and min travel point in clockwise and counterclockwise. Then push/pull the trigger to forward/backward as far as it will go. The wheel and trigger go back to the neutral position. Once calibration is finished by press the bind key to save and exit.

- If the calibration is completed successfully, the transmitter will exit calibration mode by pressing BIND button, meanwhile the buzzer will prompt with one short beep, and afterwards, the transmitter is in standby mode with the LED in three-flash-one-off state.
- If the calibration is failure, the transmitter can not exit the calibration mode by pressing BIND button.

用于方向手轮和油门扳机的中位角度修正。

发射机在出厂前已校准完成，如需要重新校准，请按照以下步骤执行。

- 1、将发射机手轮顺时针打到最大，前推油门扳机至最大，并将 POWER 键拨至 [ON] 位置，即进入摇杆校准模式（指示灯常亮），蜂鸣器短响一声循环提示；
- 2、将手轮和扳机行程打到最大和最小时，回至中位位置。然后按 BIND 键保存并退出校准模式。
 - 若校准成功按 BIND 按键可退出校准模式，蜂鸣器短响一声循环提示，随后发射机进入待机模式（指示灯三闪一灭）；
 - 若校准未通过，按 BIND 按键无效，即不能退出校准模式。

Power Off 关机

Follow the steps below to turn off the system:

1. Disconnect the receiver power.
2. Toggle the transmitter's Power Switch to the OFF position.

请按照以下步骤关机：

- 1、断开接收机电源；
- 2、将 POWER 键拨到 [OFF] 位置，使发射机关闭。



Make sure to disconnect the receiver power before turning off the transmitter. Failure to do so may lead to damage or serious injury.

关闭时，请务必先关闭接收机电源，再关闭发射机，否则可能导致模型损坏、人员受伤。

System Functions

系统功能

Channel Description 通道说明

The transmitter outputs a total of 3 channels, the function assignment and settings are as follows.

该发射机共输出 3 个通道，功能分配及设置如下：

Channel 通道	Assigned Control 已分配的控件	Function 功能
CH1	Steering Wheel 方向手轮	Steering (To make the model car to turn right or left.) 方向 (控制车子左右转向。)
CH2	Throttle Trigger 油门扳机	To control the model car to move forward or backward.) 油门 (控制车子前后行驶。)
CH3	Three-position switch CH3 三档开关 CH3	Fast-Median-/slow-position servo channel, to switch the speed positions of the model car. Toggle the control to switch between fast-position and slow-position. 快中慢档舵机通道，切换车子速度档位。 拨动控件切换快档和慢档。

Drag brake function (default:0%) ,factory setting 100% + brake function (default: without brake) ,factory setting without brake 拖刹功能(默认:0%),厂设为100% + 刹车功能(默认:没刹车) 厂设为无刹车

Under normal power-on, quickly press the REV button twice within 1 second to enter the mode, and the green light will flash. Select the appropriate drag brake setting value as shown below, press the corresponding button, and then quickly press the REV button twice within 1 second to exit.

ST-: 0%

ST+: 50%

TH-: 75%

TH+: 100%

Press the BIND button to cycle through with and without brake.

正常开机状态下, 1秒内快速按REV按键两下进入模式, 此时绿灯闪亮, 在下列按键里选取所需拖刹设定值, 按一下选定, 再快速按REV按键两下退出模式。

ST- 为 0%

ST+为 50%

TH- 为 75%

TH+ 为 100%

短按BIND按键循环切换带刹车和不带刹车功能。

Trims and travel of gear shift servo 换档舵机微调/舵量

Under normal power-on, quickly press the BIND button twice within 1 second to enter the mode, and the green light will flash. Press the corresponding button to adjust to the appropriate state, and then quickly press the BIND button twice within 1 second to exit.

ST+/-: Increases /decreases adjustment step

TH+/-: Increases /decreases servo travel

正常开机状态下, 一秒内快速按BIND按键两下进入模式, 此时绿灯闪亮, 短按下列按键调整至所需状态后, 快速按BIND按键两下退出模式。

ST-/+ 为换档舵机微调

TH-/+ 为换档舵机舵量

Channel Reverse 通道反向

To reverse the output direction of the channel.

- When the steering wheel is located in the maximum travel or minimum travel, press the REV button to reverse CH1. When you press once, it switches once.
 - When the throttle trigger is at the maximum or minimum travel and the steering wheel is in the neutral position at the same time, press the REV button to reverse CH2. When you press once, it switches once.
- When the reverse action of the channel takes effect, the buzzer will sound shortly for prompt.

Note: Pay special attention on throttle channel reverse operation due to safety concern, as the model car will move in full speed when the trigger is at full throttle position!

该功能用于调整通道的动作方向。

- 方向手轮位于最大行程或最小行程时, 按 REV 按键可使通道 1 反向, 按一次切换一次;
- 油门扳机位于最大行程或最小行程时, 同时方向手轮位于中位时, 按 REV 按键可使通道 2 反向, 按一次切换一次。通道反向动作生效时, 蜂鸣器短响一声提示。

注: 油门通道反向时, 请注意安全(最大油门时车子会以全速运动)!

Trims 微调

To adjust the trim value of the channel.

- When the steering wheel is in the neutral position, press the ST+/- button to adjust CH1 trim.
- When the throttle trigger is in the neutral position, press the TH+/- button to adjust CH2 trim.

ST+/TH+: Increase the trim value. ST-/TH-: Decrease the trim value. Trim range: -150 us – 150 us; The step is 5us; by default, it is 0.

When the trim setting action takes effect, the buzzer will sound shortly for prompt. If you press and hold it, the value remains changes continuously. The buzzer will sound twice for prompt when the trim is across the neutral position. And when it reaches the endpoint, the buzzer will sound long for prompt.

该功能用于调整通道微调。

- 当方向手轮位于中位时，按 ST+/- 按键，可调整通道 1 微调；
- 当油门扳机位于中位时，按 TH+/- 按键，可调整通道 2 微调。

ST +/TH+: 增大微调值，ST -/TH-: 减少微调值，微调调节范围: -150us~150us，调节步进为 5us，默认为 0。

微调设置动作生效时，蜂鸣器短响一声提示，长按快速调节，微调过中位时，蜂鸣器响两声提示；到终点时长响一声提示。

D/R 舵量调节

To adjust the trim value of the channel.

- When the steering wheel is in the neutral position, press the ST+/- button to adjust CH1 trim.
- When the throttle trigger is in the neutral position, press the TH+/- button to adjust CH2 trim.

ST+/TH+: Increase the trim value. ST-/TH-: Decrease the trim value. Trim range: -150 us – 150 us; The step is 5us; by default, it is 0.

When the trim setting action takes effect, the buzzer will sound shortly for prompt. If you press and hold it, the value remains changes continuously. The buzzer will sound twice for prompt when the trim is across the neutral position. And when it reaches the endpoint, the buzzer will sound long for prompt.

该功能用于调整通道的舵量。

- 方向手轮位于最大行程或最小行程时，按 ST+/- 按键，可调节通道 1 舵量；
- 当油门扳机方向手轮位于最大行程或最小行程时，按 TH+/- 按键，可调节通道 2 舵量。

ST+/TH+: 增加舵量值，ST-/TH-: 减小舵量值，调节范围: 0-120%（默认 100%），步进为 5%。

舵量设置动作生效时，蜂鸣器短响一声提示，长按快速调节，舵量至终点时，蜂鸣器长响一声提示。

Failsafe 失控保护

The failsafe function is used to protect the model and personnel when the receiver is out-of-control. The CH2 will be in brake mode when the receiver is out-of-control.

By default, and the receiver will keep outputting the last channel value in case of out-of-control.

- When the transmitter is in normal working state, press and hold the BIND button for 3S to start the failsafe function. The current channel value is set as the failsafe value. The buzzer will sound long for prompt after the setting is successful.

Note: When the transmitter binds with a receiver once more, the failsafe setting will restore to default setting

此功能用于当接收机无法正常收到发射机的信号不受控制时，保护模型和操作人员的安全。失控后 CH2 通道进入刹车状态。该发射机默认未设置时接收机通道保持最后输出。

- 开机正常状态下，长按对码按键 3S 触发失控保护设置，将当下的通道值作为失控保护值。动作设置成功时，蜂鸣器长响一声提示。

注：重新对码时恢复默认设置。

Reset Data 数据复位

To reset the function data.

- Press and hold the BIND button and REV button while powering on the transmitter, to reset the function data, and the buzzer will sound long for prompt.

Note: The failsafe setting, binding information and stick calibration will not be reset.

此功能用于将发射机功能参数恢复为默认值。

- 按住发射机的 BIND 键和 REV 键后，并将 POWER 键拨至 [ON] 位置，即恢复数据，蜂鸣器长响一声提示。

注：失控保护设置、对码信息和摇杆校准数据不复位。

Idle Alarm 闲置报警

The transmitter will go into idle alarm state when there is no operation over 10 minutes.

- When the transmitter is in idle alarm state, the transmitter LED is in gradual light state, the buzzer sounds twice quickly in cycle for prompt. Operations of any control on the transmitter will cancel the alarm, as a result of the exit of the idle alarm state.

当发射机未操作时间大于 10 分钟时，即进入闲置报警状态。

- 在此状态下，发射机指示灯为呼吸灯闪烁状态，蜂鸣器循环快响两声提示；操作发射机上的任意控件将解除并退出闲置报警状态。

Sleep Mode 休眠模式

When the transmitter has been in idle alarm state over 2 minutes, it will enter the sleep mode.

- In this mode, the transmitter LED is in gradual light state, the buzzer is off and the RF is off. The transmitter will enter low power consumption state, and no responsive in case of operations of any control. To exit the sleep mode, power off the transmitter and restart it.

当发射机处于闲置报警状态时间大于 2 分钟时，即进入休眠模式。

- 在此模式下，发射机指示灯为呼吸灯闪烁状态，蜂鸣器关闭，RF 关闭，发射机将停止一切工作，进入低功耗休眠状态。此时操作任意控件发射机都无响应。必须关闭电源重启发射机才能退出休眠模式。

Low Voltage Alarm 低电压报警

When the transmitter voltage has lower than 4.2V, it will enter the low voltage alarm state.

- When the transmitter is in low voltage alarm state, the transmitter LED will be in gradual status and will sound shortly for prompt. the buzzer.

Note: The RF is off when the batteries voltage is lower than 3.5V for the model's and the system's safety.

当发射机电池电压低于 4.2V 时，即进入低电压报警状态。

- 在此状态下，发射机指示灯为慢闪状态，蜂鸣器短响一声循环提示。

注：为保护系统和模型的安全，电池电压低于 3.5V 时，无线系统将停止工作。

Offline Prompt 离线提示

When the transmitter is in normal state, once it detects the bound receiver has turned off, or disconnected over 2S, the transmitter LED will be in three-flash-one-off state for prompt.

Note: When the transmitter received the information of the bound receiver again, it will exit the offline prompt state.

当发射机在正常工作状态下，检测到已对码的接收机未开机、已关机或掉码时间大于 2S 时，发射机指示灯三闪一灭提示。

注：若收到已对码的接收机回传信息后，即退出离线提示状态。

Attentions 注意事项

- Make sure the product is installed and calibrated correctly, failure to do so may result in serious injury.
- Make sure the receiver's battery is disconnected before turning off the transmitter, failure to do so can result out of control. Unreasonable setting of the Failsafe may cause accidents.
- Make sure the receiver is mounted away from motors, electronic speed controllers or any device that emits excessive electrical noise.
- Keep the receiver's antenna at least 1cm away from conductive materials such as carbon or metal.
- Do not power on the receiver during the setup process to prevent loss of control.
- 使用前必须确保本产品与模型安装正确，否则可能导致模型发生严重损坏。
- 关闭时，请务必先关闭接收机电源，然后关闭发射机。如果关闭发射机电源时，接收机仍然在工作，将会导致遥控设备失控。失控保护设置不合理可能引起事故。
- 确保接收机安装在远离电机或电子噪声过多的区域。
- 接收机天线需远离导电材料，例如金属棒和碳物质。为了避免影响正常工作，请确保接收机天线和导电材料之间至少有 1 厘米以上的距离。
- 准备过程中，请勿连接接收机电源，避免造成不必要的损失。

Protect Function 保护功能

The receiver has low voltage protection and overheating protection function.

- Low voltage protection: When the voltage of the receiver is lower than 6.4V, all channels have no output.
- Overheating protection: When the receiver temperature is too high, CH2 motor channel has no output and CH1 channel has normal output. When the temperature returns to be normal, the overheat protection function becomes unavailable, that is, the normal output of CH2 resumes.

本款接收机具有低压保护和过热保护功能。

- 低电压保护：接收机电压低于 6.4V 时，所有通道无输出。
- 过热保护：当接收机温度过高时，CH2 马达通道无输出，CH1 通道正常输出；当温度恢复正常时，则退出过热保护功能，即 CH2 恢复正常输出。

LED Light Control 车灯控制

When the receiver and the transmitter has connected normally, press the BIND button to turn on or turn off the car light. By default, the car light is off.

在发射机与接收机正常通信状态下，短按发射机 BIND 按键开或关闭车灯。默认为关闭状态。

Failsafe 失控保护

The receiver supports the failsafe function, it needs to be set at the transmitter side, refer to Failsafe for details.

本接收机支持失控保护功能，需要发射机端设置，操作步骤请查看 [失控保护]。

Connecting the battery 连接电池

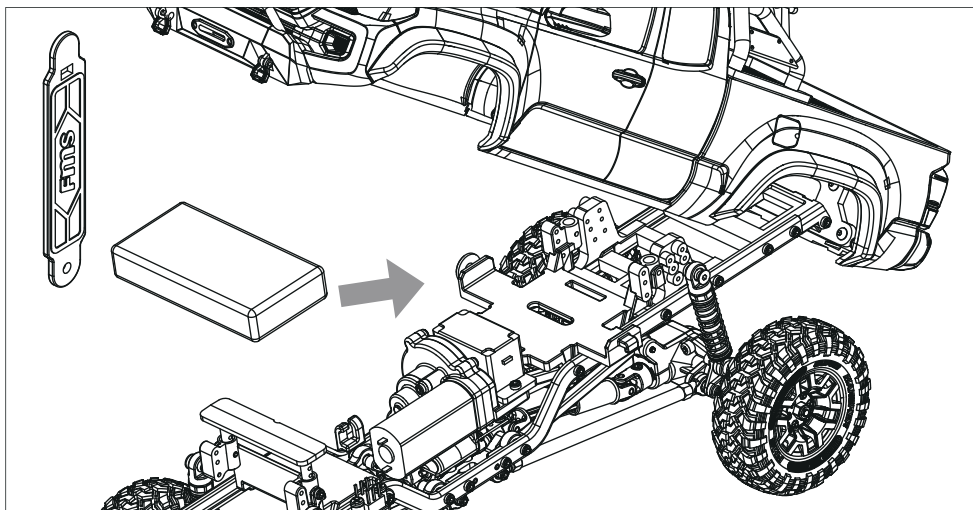

Release the hook and loop fastener to separate the shell body from the chassis from the front end as shown, load the battery into the battery compartment. Connect the battery plug to the female connector of the receiver/ESC combo unit, and then close the engine hood.

The battery plug :51005 2P Male

Battery compartment size : 53*21*17mm

NOTE

1. If it is not in use for a long time, unplug and take off the battery to prevent battery leakage.
2. Do not open, disassemble, or attempt to repair the battery.
3. The battery needs to be disconnected from vehicle before it can be charged
4. Do not charge battery in vehicle.

如图所示，如图所示，分开魔术贴，从前端分离车壳与车底盘；将电池插头连接到接收机/电调一体装置的母头，然后关闭引擎盖。

电池插头:51005 2P 公头

电池仓尺寸：53*21*17mm

注意：

- 1、如果长时间不用，请拔下电池，以防电池损坏。
- 2、不要打开、拆解或试图维修电池。
- 3、在给电池充电之前，需要先断开电池与车辆的连接。
- 4、请勿在车内给电池充电。

Battery Precautions 电池注意事项

- Never charge a lithium polymer battery with a charger designed for Nicd, NIMH, or any other type of battery chemistry. Use ONLY charger designed for LiPo battery.
- Do not leave LiPo battery unattended during charging.
- Do not overcharge the battery.
- Always charge LiPo batteries on non-flammable, heat-resistant surfaces.
- Always use a LiPo-safe bag or container while charging. Do not allow LiPo cells to overheat at any time. Cells which reach greater than 140 Fahrenheit(60°C) will usually become damaged and will catch fire.
- Do not charge the LiPo pack while it is still in the model. Never charge or store battery packs in a vehicle.
- Do not discharge LiPo, doing so will damage the battery.
- Do not expose LiPo cell to water or moisture at any time.
- Do not store battery near open flame or heater.
- Do not assemble LiPo cells or pre-assembled packs together with other LiPo cells or packs.
- Always store LiPo battery in a secure location away from children.
- Always remove the LiPo battery if model is involved in any kind of crash.
- Carefully inspect the battery and connectors for even the smallest damage.
- CAUTION: Cells may become hot after usage. Allow the pack to cool to room temperature prior to recharging.
- Do not allow the electrolyte to get into eyes or on skin. Wash affected areas immediately if they come into contact with electrolyte.
- Do not alter or modify connectors or wires of a LiPo battery pack.
- Always inspect the condition of the battery before charging and operating.
- Do not short circuit the LiPo battery.
- Do not have contact with a leaky/damaged battery directly.
- Do not charge battery out of recommended temperature range(0°C-45°C).
- 不要使用Nicd、NIMH或任何其他类型的充电器给LIPO锂聚合物电池充电。请使用LIPO锂聚合物的专用充电器给LIPO锂聚合物电池充电。
- 请勿在无人看管的情况下充电。
- 电池请勿过充。
- 请勿将电池放置在易燃、不耐热的表面上充电。
- 总是使用安全袋或安全容器给电池充电。保证电池在任何时候都不过热。电池温度超过140华氏度（60°C）则易造成损坏，甚至引发火灾。
- 请勿将电池长期置于模型产品内，更勿在模型产品内直接充电。
- 请勿给电池放电，以免损坏电池。
- 任何时候请勿将电池暴露在水或湿气之中。
- 请勿在明火或加热器附近储放电池。
- 请勿与其他未组装或预组装的电池混用。
- 需将电池存放在远离儿童的安全位置。
- 模型如出现任何碰撞，需立刻拆除电池。
- 即使出现微小的损坏，也需仔细检查电池和连接器。
- 注意：使用后电池可能会发热，需让电池冷却到室温后再进行充电。
- 请勿让电解液接触眼睛或皮肤。如电解液不慎接触到身体的任何部位，请立即进行清洗。
- 请勿替换或修改电池组的连接器或电线。
- 在进行充电或其他任何操作之前需检查电池的状况。
- 请勿造成电池短路。
- 请勿直接接触已泄漏或已损坏的电池。
- 请勿超出建议温度范围充电电池（0度-45度）。

Spare Parts List

配件列表

C4000	Car Body Assembly With Painted Blue	车壳总成(蓝色)
C4001	Car Body Assembly With Painted Red	车壳总成(红色)
C4002	Car Body Assembly With Painted Gray	车壳总成(灰色)
C4003	Wheel Assembly Set	车轮套装总成
C4004	Wheel Set	轮毂 (一对)
C3401	Tire Set	轮胎套装
C3402	Oil Shock Absorbers Parts 1pair (W/O Spring)	避震器散件一对(不带弹簧)
C3688	Front Shock Spring	前避震弹簧
C3689	Rear Shock Spring	后避震弹簧
C3403	Front Axle Assembly	前桥总成
C4005	Rear Axle Assembly	后桥总成
C4006	Transmission Gear Box Assembly	驱动牙箱总成
C3406	Transmission Gear Box Housing	驱动牙箱壳胶件
C3407	050 Motor Set	050 电机套装
C3408	Variable Speed Servo	换档舵机
C3409	Gear Set For Transmission Gear Box	变速箱齿轮
C3410	11t Pinion Gear	11T 电机齿
C3411	Pin And Shaft For Transmission Gear Box	变速箱轴
C3412	C Hub Set	C座套件
C3413	Front Axle Plastic Parts	前直桥胶件
C3415	Universal Drive Shaft Set Front	前轮传动轴组
C3416	Gear For Axle	直桥齿轮
C3417	Hex Wheel Adapter And Pin	车轮六角接合器及轴针
C3418	Steering Servo Mount	转向舵机固定座
C3419	Steering Linkage Set	转向连杆套装
C3420	Steering Servo Saver Set	转向舵机保护器套装
C4007	Transmission Shaft Assembly	传动轴总成
C3422	Ball Bearing Set	滚珠轴承
C3423	Rear Wheel Shaft	后轮轴
C4008	Metal Frame Rail Set	金属大梁
C3425	Battery Mount	电池座
C3426	Battery Holder	电池固定带
C3427	Esc Mount & Switch Mount	电调座及开关固定座
C3428	Transmission Gear Box Mount	驱动牙箱固定座
C3431	Car Body Mount Set	固件件套装
C3432	Ball Head	波头
C1253	M2 Screw Nut Black	M2防滑螺母黑
C3433	M1.4 Ball Head Screw	M1.4球轴
C3434	Variable Speed Servo Horn Set	换档舵机臂套装
C3181	G3 Transmitter V3	G3 发射器 V3
C3435	Steering Servo	转向舵机
C4009	Wheel Brow Set	轮眉组
C4010	Window	车窗玻璃
C4011	Blister Seat Compartment	吸塑座仓
C4012	Rear Bumper Set	后防撞套装
C4032	Rooftop Rack Assembly	行李架总成

Spare Parts List

配件列表

C4015	Front Bumper A	前防撞A
C4016	Front Bumper B	前防撞B
C4017	Front Grille A	前格栅A总成 (带logo)
C4018	Front Grille B	前格栅B总成 (带logo)
C4019	Rearview Mirror And Wiper	后视镜及雨刮
C4020	Rear Door And Handle Red	尾门及拉手 红
C4021	Rear Door And Handle Blue	尾门及拉手 蓝
C4022	Rear Door And Handle Gray	尾门及拉手 灰
C4023	Tacoma Logo	侧身贴纸
C4024	Hood Red	前引擎盖 红
C4025	Hood Blue	前引擎盖 蓝
C4026	Hood Gray	前引擎盖 灰
C4027	Truck Bed Red	后斗板 红
C4028	Truck Bed Blue	后斗板 蓝
C4029	Truck Bed Gray	后斗板 灰
C4030	Light Cup Set	全车前后灯杯
C4051	Light Control Wire	灯线
C3456	Hook And Loop 20*10 3m Tape	魔术贴 20*10 3M背胶
C3516	Wire Mount	线夹
C1389F	Fms Lipo Battery 2s 7.4v 380mah	FMS 电池7.4V 2S 380mAh
C3638	Brass Wheel Counterweight	配重接合器
C3675	Fms Land Rover Camel Trophy Commemorative Gift Packs (W/o Battery Pack)	FMS路虎系列纪念礼包 (不含电含)
C3691	Double-sided Gummed Tape	双面贴
C3754	G3 + R3a Transmitter Receiver Set For Fcx24m	G3 + R3A 发射器/电调接收器 FCX24M专用
C3755	R3a Receiver For Fcx24m	R3A 电调接收器 FCX24M专用
C3756	Spur Gear 70t 0.3 (Pom)	大齿 70T 0.3 (POM)
C3760	Cross Join	十字轴
C3407V2	050 Motor Set V2	050 电机套装 V2
C3785	Differential Set	差速器套装
C3787	11t Pinion Gear Brass	11T 电机齿(黄铜)
C3792	Transmission Gear 17t (Steel)	17T 变速箱齿轮 (钢)
C3413V2	Front Axle Plastic Parts V2	前直桥胶件 V2
C3414V2	Rear Axle Plastic Parts V2	后直桥胶件 V2
C4031	Screw Set	螺丝包
C3986	Gear M0.3-t17 Steel	齿轮 M0.3-T17 不锈钢

